

Remote Signal Activator

[GATE / SEMAPHORE ACTUATOR]

800-8100

CONGRATULATIONS!

Your new Remote Signal Activator (RSA) will now allow you to use the TORTOISE™ to drive any scale crossing gate or semaphore-style signal that has a vertical actuating wire extending through the layout base. The actuator features positive, screw-adjusted stops at both the vertical and horizontal positions. Stops at the mid-position for 3-color semaphore arms can be easily accomplished by utilizing a CIRCUITRON SD-2 (800-5520) Semaphore Driver Circuit. By purchasing an extra RSA Cable and Actuator (part no. 800-8101), one TORTOISE™ can simultaneously drive two gates at one crossing.

HOW IT WORKS

The TORTOISE™ mounts to the drive mechanism and can be located up to 18" from the signal. A drive arm with multiple pivot holes (for adjusting the total throw) moves a slide back and forth as the TORTOISE™ runs (crawls?). A fine stainless steel wire is clamped to the slide and moves inside a small teflon™ tube, much like a sub-miniature choke cable. At the other end of the wire and tube, an actuator bellcrank is swung by the moving wire. Multiple holes are provided in the bellcrank to accommodate virtually any vertically actuated signal wire.

Fully adjustable screw stops are provided to set the range of motion precisely. The drive mechanism assembly with the TORTOISE™ mounted on it can be located in any position above or below the layout surface. It may even be possible to locate the mechanism inside of larger structures if that would be an advantage.

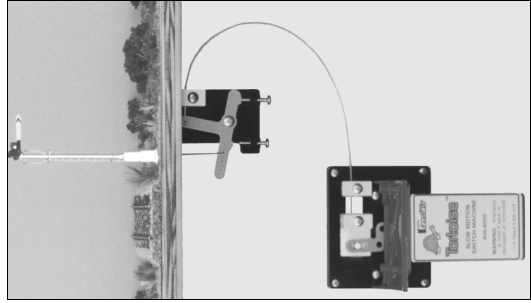

CONTENTS

Please check your kit carefully and refer to the drawings to identify all parts. You should have:

- (1) Drive Mechanism Base Plate
- (1) TORTOISE™ Mounting Plate
- (1) Drive Mechanism Arm
- (1) Slide
- (1) Slide Clamp Plate (4 Shallow Grooves)
- (1) Base Clamp Plate (4 Deep Grooves)
- (1) Bellcrank Mounting Plate
- (1) Actuator Clamp Plate (2 Deep Grooves)
- (1) Bellcrank
- (14) #4 x 3/8" Phillips Truss (large) Head Screws
- (6) #4 x 5/8" Phillips Pan Head Screws
- (2) #4 x 1/2" Phillips Shoulder Screw
- (1) 18" Length Stainless Steel Wire
- (1) 18" Length Teflon Tube

CAUTION: Handle the Stainless Steel Wire and Teflon Tube carefully to avoid kinking either of them. Kinks will degrade performance and may render the mechanism unusable. Replacement Wire/Tube sets are available from Circuitron for \$3.00 postpaid.

TOOLS REQUIRED

- #1 Phillips Screwdriver
- Diagonal Wire Cutters (Hardened or Heavy Duty)
- Flush Cutting Nippers
- Needle Files
- Square Jawed Needle Nose Pliers
- Abrasive Cutoff Disc in Motor Tool
- Drill with 3/32" drill bit.
- Hobby Knife with new (sharp) #11 Blade
- ACC-Adhesive (Thin)

PREPARING THE PARTS

Remove all parts from their sprues, if necessary, and trim the gate vestiges with flush cutters. File the trimmed surface smooth on the Slide.

GETTING STARTED

- 1) Determine the total travel of the signal you want to actuate by holding a caliper, ruler or scale next to the wire under the layout and moving it between both extremes. Refer to the chart in the next column and make a note of the recommended pivot hole and Bellcrank hole to use for your application.

NOTE: The numbers in the chart are just suggestions and should provide a small amount of desirable over-travel for most applications. However, the length of cable and friction of the actuated device may affect the operation and you may need to choose a hole combination that provides somewhat more total travel.

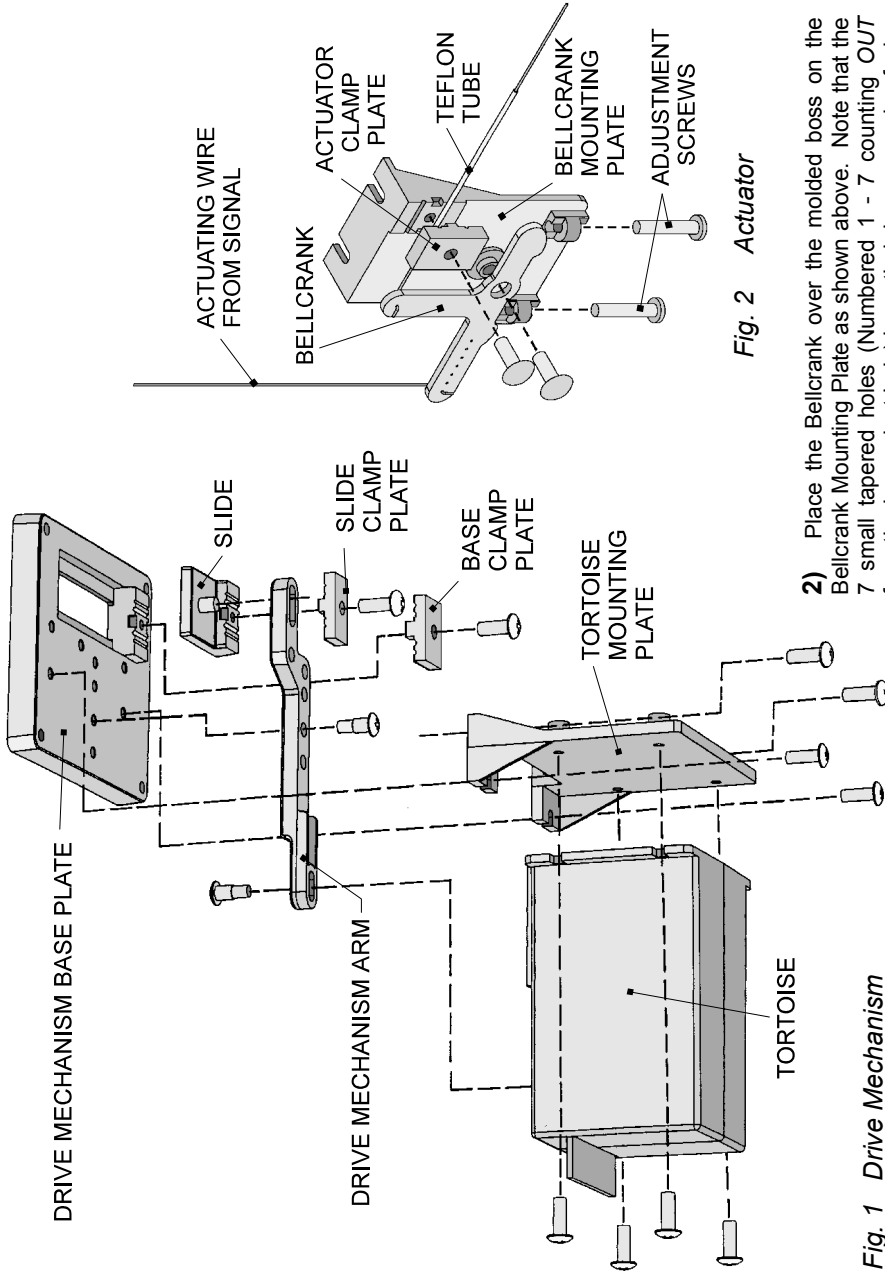

Fig. 1 Drive Mechanism

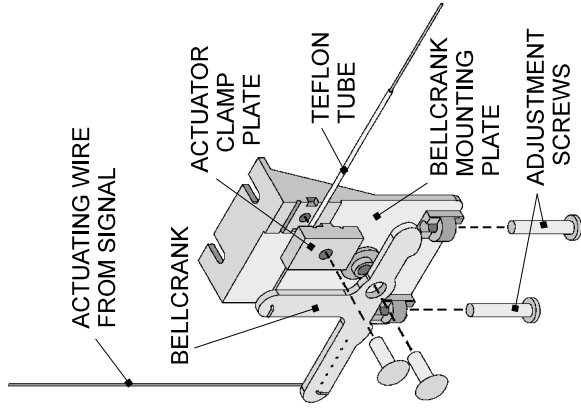

Fig. 2 Actuator

- 2) Place the Bellcrank over the molded boss on the Bellcrank Mounting Plate as shown above. Note that the 7 small tapered holes (Numbered 1 - 7 counting OUT from the large pivot hole) have their larger opening facing toward the Mounting Plate. Insert a # 4 x 3/8" Phillips Truss Head Screw into the hole in the boss and tighten until just snug. The Bellcrank should still move freely.
- 3) Place the Bellcrank and mounting plate next to the signal actuating wire with the mounting flange against the underside of the layout. Adjust the Bellcrank so that the lower arm with all the holes in it is horizontal. Position the assembly so that the wire passes directly over the Bellcrank hole number determined in step 1.

EXAMPLE: The 2nd hole (in combination with Drive Mechanism Pivot Number 3) is usually ideal for use with signals that have a little over 1/8" (.135") total travel such as Tomar's HO Scale semaphores and NJ International's HO Scale gates. If your signal's travel is different, it will be necessary to use a different hole combination.

- 4) Using a fine tip marker, make a mark on the signal wire directly over the hole in the Bellcrank. Also mark the two mounting locations on the underside of the layout. Remove the Bellcrank from the Mounting Plate.

Total Signal Actuator Wire Travel in Inches	Drive Mechanism Pivot Number	Bellcrank Hole Number
.035 - .049	1	1
.050 - .069	1	3
.070 - .089	2	2
.090 - .109	2	4
.110 - .129	3	1
.130 - .150	3	2
.155 - .175	3	3
.180 - .200	3	4
.205 - .230	3	3
.235 - .265	4	1
.270 - .300	4	2
.305 - .340	4	3
.345 - .385	4	4
.390 - .440	4	5
.445 - .495	4	6
.500 - .540	5	4
.545 - .610	5	5
.615 - .680	5	6
.685 - .750	5	7

- 5) Holding the wire with pliers, bend it to 90 degrees at the mark.
- 6) Drill two 3/32" pilot holes at the locations you marked in Step 4 and temporarily mount the Bellcrank Mounting Plate with two # 4 x 3/8" Phillips Truss Head Screws.

- 7) Drill out the selected hole in the Bellcrank with a drill-bit in a pin vice sized to match the diameter of the signal actuating wire.
- 8) Prepare the stainless steel wire by cutting 1/4" off of one end. **CAUTION: This wire is quite hard and will destroy delicate cutters. Use good quality hardened cutters or use the abrasive cutoff wheel.** Run the cut end through your fingers and make sure there are no burrs or hooks on the end.

HANG IN THERE!

IT'S GOING TO TAKE YOU FAR LESS TIME TO DO THE INSTALL THAN TO READ ALL THE INSTRUCTIONS.

LOCATING THE DRIVE MECHANISM

It is desirable to locate the Drive Mechanism with the TORTOISE™ attached as physically close to the Actuator as possible. Shorter cable lengths result in smoother action and more positive throws. Although the cable can be up to 18" long, you should shorten it if space permits. Select a location for the Drive Mechanism Base Plate near the actuator and temporarily tape or screw it in place. Tape one end of the Teflon tube in the Actuator Clamp groove and then place the tube in the Base Plate Clamp groove. The goal is to find a location for the Drive mechanism where the Teflon tube will have a minimum of bends and also the shortest overall length (short and as straight as possible is what we're after here). No bend should have less than a 2" radius (4" minimum preferred).

- 9) After finding the best location, make a mark on the Teflon Tube with a permanent felt tip marker at the center of the Base Plate Clamp groove. **CAUTION: HANDLE THE TEFLON TUBE WITH CARE. DO NOT KINK!** Also mark the locations of the four corner mounting holes. Loosen the two mounting screws slightly and remove the Bellcrank Mounting Plate.

COMPLETING THE ACTUATOR

- 10) Using the sharp hobby knife or a single edge razor blade, cut the Teflon Tube to a length 2" LONGER than the mark on the tube you made above.
- 11) Carefully thread the previously cut end of the stainless steel wire into one end of the cut Teflon Tube. Thread it through until it extends a few inches out the other end.
- 12) Make a 90 degree bend in the stainless steel wire about 3/8" in from the trimmed end.
- 13) Locate the small single hole near the end of the Bellcrank vertical arm and note that the hole is tapered.

Feed the wire through the arm from the larger side so that it exits the tiny opening on the other side. (If it doesn't want to go through, it may be necessary to enlarge the hole slightly with a #75 - 80 drill bit in a pin vise.) Bend the end of the wire over into a "Z" shape, capturing it in the Bellcrank arm.

- 14) Place the Bellcrank back in position on the Mounting Plate and re-insert the Truss Head Screw. Lay the Teflon Tube in the Mounting Plate clamp block groove so that the end of the tube is flush with the inside edge of the clamp block. Place the Clamp Plate on top and *making sure that the tube is fully seated in the groove*, press it down in place. Use a # 4 x 3/8" Phillips Truss Head Screw to clamp the plate tightly to the block.

- 15) Position the Actuator Mounting Plate / Bellcrank assembly back in position under the screwheads and tighten in place. Insert the signal actuating wire into the proper hole in the Bellcrank and then bend the signal wire into a 'Z' shape to capture it in the Bellcrank. Hold the Teflon Tube in one hand and move the stainless wire in and out with the other. The signal should move smoothly and without binds to the extremes of its motion.

- 16) Carefully thread 2 Adjustment Screws (# 4 x 5/8" Phillips Pan Head) into the molded openings at the bottom of the Bellcrank Mounting Plate until the end of the screw is flush with the edge of the raised area.

ASSEMBLING THE DRIVE MECHANISM

The Drive Mechanism can be set for 5 different total travel lengths. The pivot holes are numbered 1 through 5 with number 1 being closest to the Slide.

1st Pivot Hole	.125" Total Travel
2nd Pivot Hole	.150" Total Travel
3rd Pivot Hole	.275" Total Travel
4th Pivot Hole	.490" Total Travel
5th Pivot Hole	.675" Total Travel

Refer to the chart in the third column to determine the recommended Pivot Hole for your application.

- 17) Drill 4 pilot holes 1/2" deep at the locations you marked in Step 9. Use a 3/32" drill bit.

- 18) Place the Slide in the recessed area of the Base Plate so that the raised Clamp Block on the Slide is next to the raised Clamp Block on the Base Plate.

- 19) Place the end of the Drive Mechanism Arm with the longest slot over the molded pin on the Slide so that the 5 Pivot Holes in the Arm line up with the molded holes in the Base Plate.

- 20) Place a # 4 Shoulder Screw in the correct Pivot Hole and screw it into the base. Tighten gently, then back out 1/8 turn. The Arm (and Slide) should move easily back & forth.
- 21) Partially thread 2 Truss Head Screws into the

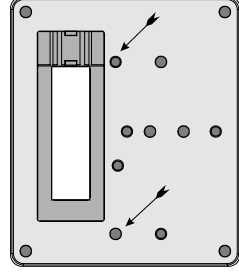

holes indicated.

22) Slip the mounting flanges on the TORTOISE™ Mounting Plate under the two screw heads. The smooth side of the Plate faces AWAY from the Slide.

23) Screw 2 more Truss Head Screws through the remaining two slots in the Mounting Plate into the Base and tighten all four screws securely.

24) Attach the TORTOISE™ to the smooth side of the Mounting Plate with 4 additional Truss Head Screws.

25) Align the Drive Mechanism Arm with the TORTOISE™ arm projecting through the case. Insert the final # 4 Shoulder Screw into the molded hole in the TORTOISE™ arm. *Do Not Over-Tighten!*

26) Test the operation by applying power (9-12 vDC) to the #1 and #8 terminals on the TORTOISE™ circuit board. Then reverse your connections to make the TORTOISE™ run the other way. There should be no binds and the Slide should move smoothly back and forth. Remove power.

CONNECTING THE CABLE

27) Set your signal or gate to the mid-point of its motion.

28) Examine the Slide Clamp Plate and the Base Clamp Plate. Notice that the Slide Clamp Plate has very fine grooves in its bottom surface whereas the Base Clamp Plates grooves are much deeper.

CAUTION: *These two parts are not interchangeable and are keyed to fit only the proper location. FORCING the parts in the wrong location will likely damage them and may prevent proper operation.*

29) GENTLY move the TORTOISE™ arm to the very center of its travel. *Be careful!* Applying too much force too fast may damage the gears.

30) Lay the Teflon Tube in one of the two slots in the raised Base Clamp Block closest to the center screw hole. The Stainless Steel Wire should be laying across the corresponding slot in the Slide and extending out over the Drive Mechanism Arm.

31) Place the Base Clamp Plate over the Teflon Tube and being very careful to keep the tube straight in the slots, press the Clamp Plate down. Insert a Truss Head Screw through the Clamp Plate and into the Base. The end of the tube should be barely visible projecting toward the Slide. Tighten the screw.

32) Follow the same procedure with the Wire in the Slide, making certain that it is aligned with the proper fine groove before tightening the screw. Re-check that BOTH the Tortoise and the signal remain at their mid-positions. Tighten the screw securely.

33) Cut off the excess wire projecting past the Slide Clamp with your diagonal cutters or cutoff wheel.

34) Test the operation under power and check that the signal is at the mid-point of its throw when the TORTOISE™ is at the mid-point of its throw. If the throw appears off-center, you can adjust it by loosening the Base

Clamp Plate slightly and moving the Teflon Tube one way or the other a small amount. Mount the assembly with four # 4 x 5/8 Phillips Pan Head Screws.

35) Watch the operation of your signal under power. If it tends to over-run either the horizontal or vertical position, you can adjust one or both Adjustment Screws to contact the Bellcrank and limit the motion.

36) [OPTIONAL] Once you are satisfied with the operation, you can place a TINY drop of ACC adhesive where the Teflon Tube enters the Base Clamp. Do the same for the Actuator Clamp. **DO NOT GET ANY GLUE NEAR THE ENDS OF THE TEFLON TUBE.** The adhesive will wick into the clamp and prevent the tube from ever moving, but can be removed by disassembling.

TO POWER 2 CROSSING GATES OR SIGNALS FROM ONE TORTOISE™

The Remote Signal Activator can accommodate a second Cable and Actuator (Part Number 800-8101). All instructions are the same but use the second set of slots closest to the screw hole on the Base and Slide Clamps.

DO NOT USE ANY LUBRICANTS ON THIS MECHANISM

CIRCUITRON, INC.

211 RocBaar Drive

Romeoville, IL 60446-1163

(815) 886-9010 FAX: (815) 886-9076