



Electronics for Model Railroads

211 RocBaar Dr., Romeoville, IL 60446

(815) 886-9010 FAX: (815) 886-9076

DT-4 rev. B

ROLLING STOCK DETECTOR

GENERAL DESCRIPTION: The CIRCUITRON **DT-4** is an advanced, integrated circuit detection circuit that can be used to actuate accessories, light panel lamps, etc. The **DT-4** uses tiny Opto-Sensors mounted between the rails to detect a passing train. No modifications to rolling stock are necessary, and the **DT-4** is completely bi-directional. The **DT-4** has four independent detection circuits that can be used separately or together to spot rolling stock at various locations. The **DT-4** outputs are also ideal for triggering and controlling many other CIRCUITRON items. Revision B of this circuit now has LED indicators on the board for easy adjustment of the sensitivity controls. The **DT-4** is designed to provide simplified power supply connections when multiple boards are to be connected together by providing power supply input and output terminals on opposite sides of the board. A section of CIRCUITRON's Printed Circuit Mounting Track (**PCMT**) can be used to provide simple snap-in mounting of the **DT-4** or the corner pads may be drilled out and screws and standoffs used. The **DT-4** requires a 10 - 18 volt DC input for proper operation. A filtered DC supply is preferred. If a source of filtered DC is not available, a CIRCUITRON **PS-1** or **PS-2** can be used to convert the output from the accessory terminals of your power pack to DC. Each output on the **DT-4** can control up to 250 ma. of DC current.

CIRCUIT DESIGN: The **DT-4** contains four identical, independent detection circuits which operate as follows: A small amount of current flows through the Opto-Sensor and is applied to one side of a current comparator circuit. This current is balanced by adjustment of the associated trimmer (P1-P4). When a piece of rolling stock shades the Opto-Sensor from the ambient room light, the current decreases due to the increase in resistance, and the output of the comparator turns on. This output is used to drive an NPN output transistor connected common emitter and will provide a ground at the output terminal (O1-O4) that is capable of controlling 250 ma. of DC current.

INSTRUCTIONS: The CIRCUITRON **DT-4** circuits can be connected with .110" solderless connectors or by soldering leads directly to the terminals on the printed circuit board. If soldering, use a small pencil-type iron and electronics-grade, rosin core 60/40 solder (available at Radio Shack). Use only as much heat as necessary to obtain a good joint and do not wiggle the terminal until the solder has cooled completely.

- 1) Mount the **DT-4** circuit board in a convenient location. If more than one board is necessary for your particular application, we recommend using a section of CIRCUITRON's Printed Circuit Mounting Track (**PCMT**). When using a multiple hookup, power supply connections can be bussed between boards by using small jumpers between output terminals on one board and input terminals on the next. *Do not attempt to bus between more than four **DT-4s**. Instead, run separate supply leads to each group of four.*
- 2) Mount the Opto-Sensors at the locations you wish to detect rolling stock following the instructions enclosed in the packet.
- 3) Connect one lead from each Opto-Sensor together with light gauge (22-24 ga.) wire, and then run that wire to the Sensor Drive Terminal [**SD**] on the printed circuit board.
- 4) Connect additional wires to the remaining leads of each Opto-Sensor and run them to their respective Sensor Terminals [**S1-S4**] on the **DT-4** circuit board.
- 5) Connect panel lamps or DC accessories between a positive DC supply and the respective Output Terminal [**O1-O4**] as shown in the diagram below. This power supply may be the same as the **DT-4** supply, or you may use a different DC supply for the lamps or accessories as long as both the accessory supply and the **DT-4** supply have a common ground [-] connection.
- 6) Connect a source of 10 - 18 volts DC to the [+] and [-] **IN** terminals on the circuit board.

ADJUSTMENTS: All adjustments should be made with room lighting at the level it will be at during operating sessions of the layout. Changes of room lighting may necessitate readjustment of the sensitivity controls.

- 1) Making certain that no rolling stock is shading Opto-Sensor 1 (connected to [S1]), rotate the sensitivity control P1 until LED indicator L1 turns on. The load connected to Output Terminal 1 [O1] should also be on at this time.
- 2) Rotate P1 back until the LED and the load turn off.
- 3) Rotate the control a few degrees further in the same direction to prevent unnecessary sensitivity.
- 4) Shade Opto-Sensor 1 [S1] with your hand and the output should turn on. If it does not, repeat steps one and two, but decrease the extra rotation in step three.
- 5) Repeat the above procedure for Opto-Sensors 2-4 using sensitivity controls P2-P4 to control outputs [O2]-[O4]. Monitor LEDs L2-L4 as above while making the adjustments.
- 6) If properly adjusted, an output should be on any time a piece of rolling stock is covering the corresponding Opto-Sensor. If you detect flickering of the output between cars, repeat steps 1 and 2, but decrease or eliminate step three entirely.

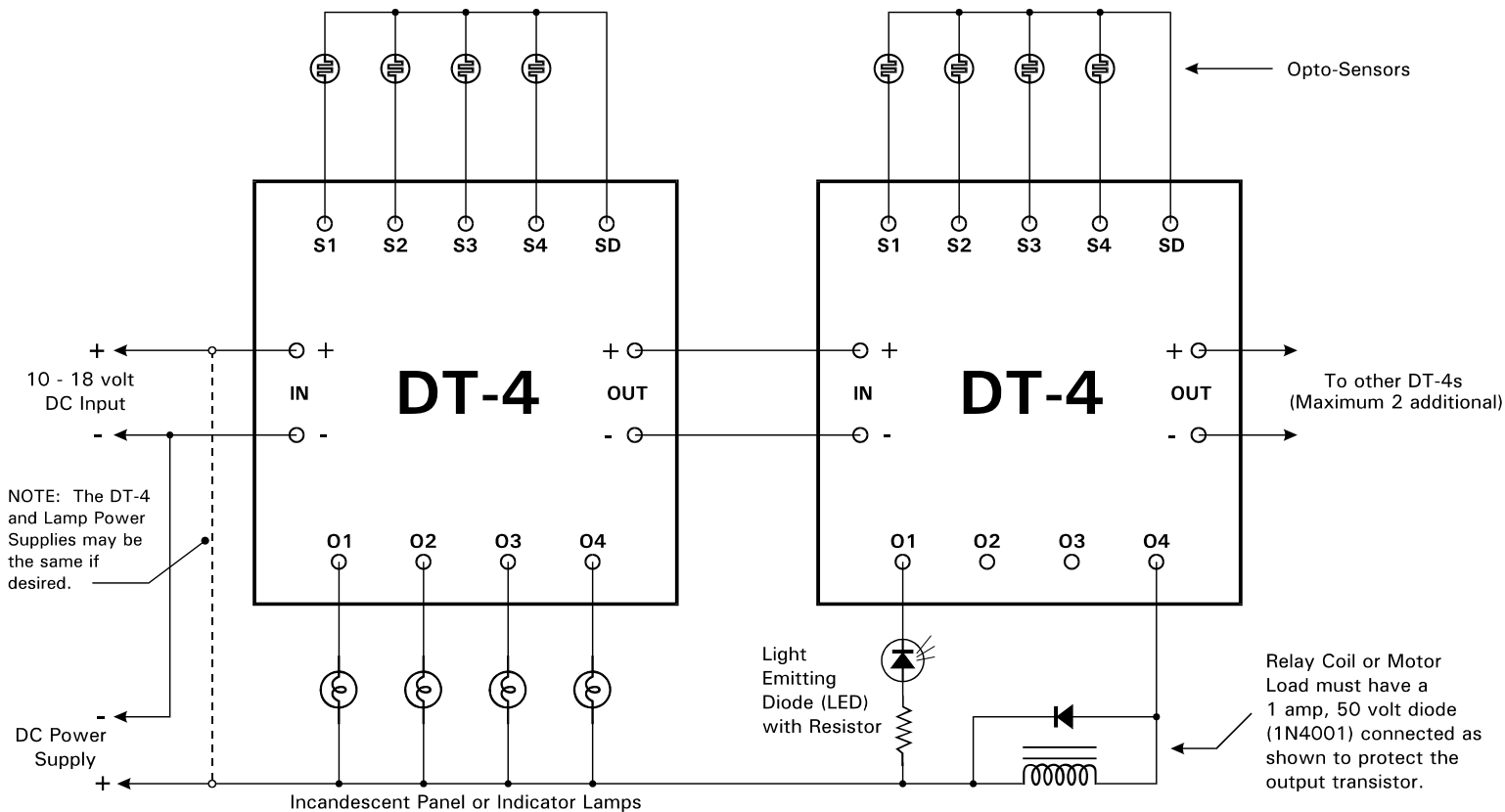

WARRANTY

CIRCUITRON warrants this device against defects in materials and workmanship for a period of one year from the date of purchase. This warranty covers all defects incurred in normal use of the device and does not apply in the following cases:

- a) *damage to the device resulting from abuse, mishandling, accident or failure to follow operating instructions.*
- b) *if the device has been serviced or modified by other than the CIRCUITRON factory.*

EXCEPT AS MENTIONED ABOVE, NO OTHER WARRANTY OR GUARANTEE, EXPRESS OR IMPLIED INCLUDING MERCHANTABILITY, ON THE PART OF THE UNDERSIGNED OR ANY OTHER PERSON, FIRM OR CORPORATION, APPLIES TO THIS DEVICE.